



AmericanAirFilter®
Type N RotoClone®
Hydrostatic Precipitator

AmericanAirFilter®

Type N RotoClone®

High Efficiency Wet Collector

The Type N RotoClone is the best solution to many dust collection needs. Combining high efficiency, low maintenance costs, simplicity, low water usage, and flexibility in one rugged, well proven piece of equipment, the Type N RotoClone has solved thousands of dust collection problems. Although the basic operating principle has remained unchanged since it was first introduced, many design enhancements have been made to provide greater efficiency and flexibility.

- **Efficient** — Designed to maximize the cleaning effect of the energy used, the Type N RotoClone can be selected to operate at medium or high efficiency, using only the energy required to meet your project's needs.
- **Low Maintenance** — Designed to provide years of service with minimal maintenance, the Type N RotoClone has no nozzles to clog. The only moving parts are the fan impeller and, if equipped with it, the automatic sludge ejector.
- **Low Water Usage** — The sophisticated water level controls keep water usage to a minimum. In fact, with the optional Model A water level controller, there is no water overflow, and water is added only to make up for that lost to evaporation or discharged with the sludge.
- **Rugged** — Assembled of heavy gauge hot rolled steel, the Type N RotoClone is designed to give many years of satisfactory performance under normal operating conditions. For highly corrosive conditions, the unit can be fabricated of stainless steel or lined with coal-tar epoxy.
- **Proven** — Thousands of Type N RotoClone collectors have been in service on a wide variety of applications since the basic type was introduced. Many have remained in service for decades.
- **Flexible** — If efficiency requirements change, a simple modification to the water level control, along with appropriate adjustment to the exhauster, allows the Type N RotoClone to operate at higher or lower efficiency.
- **Versatile** — The Type N RotoClone is available for automatic sludge ejection, manual clean-out, or sluicing; in sizes from 1,500 to 50,000 CFM; and with or without a top mounted fan. It can be tailored to meet your needs.



Arrangement C,
Type N RotoClone

Pressure Drop Versus Collection Efficiency

Collection efficiency is a function of the energy expended in the air to water contact process. Higher energy consumption provides more violent interaction and greater collection efficiency for a given particle size. Pressure drop is a measure of the energy used and is directly proportional to the power required. Since this power must be supplied at the fan or compressor, higher collection efficiencies are obtained at the expense of higher power costs. Using the minimum pressure drop which provides the required efficiency for the particle size distribution ensures the most economical equipment and operating costs.

Field Upgrade Flexibility

If your needs require higher efficiency, our special impeller design enables higher efficiency to be obtained resulting in a higher pressure drop and higher air velocity. The exhaust fan must also be evaluated to ensure it is rated correctly for the upgraded system and higher pressure drop.

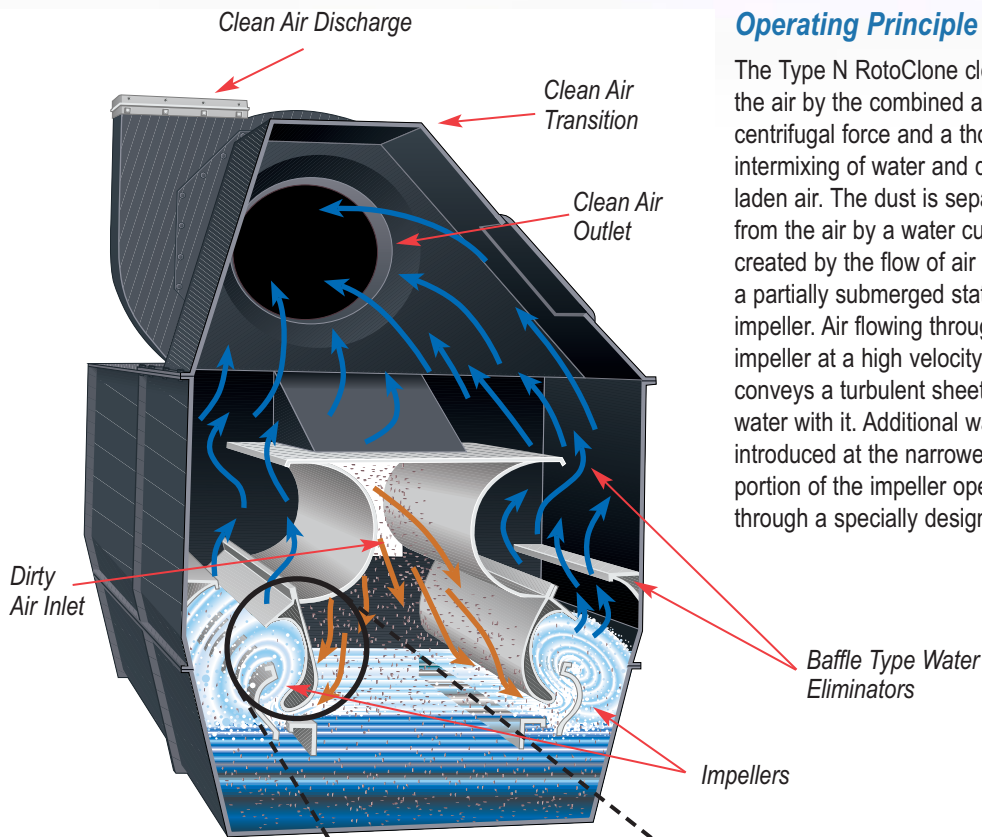

Operating principle, Arrangement B, Size 8 and larger

Operating Principle

The Type N RotoClone cleans the air by the combined action of centrifugal force and a thorough intermixing of water and dust-laden air. The dust is separated from the air by a water curtain, created by the flow of air through a partially submerged stationary impeller. Air flowing through the impeller at a high velocity conveys a turbulent sheet of water with it. Additional water is introduced at the narrowest portion of the impeller opening through a specially designed slot

in the bottom. This water flow upward through the slot creates increased interaction between the dust and water, thus increasing collection efficiency.

The centrifugal force exerted by rapid changes in direction of flow causes the dust particles to penetrate the water film and become permanently trapped.

Entrained water droplets in the cleaned air are removed by specially designed, wide-space chevron eliminators for smaller collectors or three curved de-entrainment baffles for larger collectors.

The water in the reservoir is continually used. Since the water curtain is produced by the airflow, no pumps or nozzles are required. A small amount of fresh water is supplied through the make-up water connection, to compensate for evaporation and water lost as the collected dust is removed from the unit.

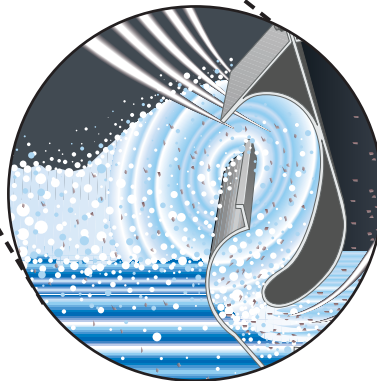

Cross section of stationary impeller

High Collection Efficiency

Efficient operation is possible on a wide range of materials and particle sizes, including the small micron range. Our unique airfoil design impeller provides such complete scrubbing of the dust-laden air that fine particles are thoroughly wetted, expanding their mass. This increased mass makes the particles susceptible to the centrifugal forces acting upon them. This enables the particles to penetrate the water film, and precipitate out of the airstream. Collection efficiencies of the Type N RotoClone are equal to or better than any wet dust collector in the industry, with comparable energy consumption.

Variable Collection Efficiency

The pressure drop of the Type N RotoClone can be varied from 5.3" to 11.7" w.g. This allows a higher efficiency for smaller, hard to collect dust particles; heavier particles; and particles smaller than design conditions.

Select from Three Water Level Control Options

Supply water make-up is required due to water losses from evaporation, dust removal, and that required at the overflow weir. The make-up water will maintain the appropriate water level by entering the RotoClone through the Water Level Control Box connection. Three types of water level controls are available:

Model SV (Solenoid Valve) Control

This is the standard water level control. It prevents operation of the RotoClone when there is insufficient water supply pressure. It also allows a continuous water flow over the running level weir, down the drainpipe, and into the overflow. The water supply system contains a fill valve, solenoid valve, strainer, pressure switch, and flow control orifice. As long as the unit operates, the solenoid remains open. When the fan stops, the solenoid valve closes and the water flow to the control box stops.

Model SV With Low Water Safety Control

This control is suitable for magnesium and other explosive dusts. In addition to the standard controls available on the Model SV Control, this model contains a low level electrode and a timing relay. It does not use the pressure switch. The low water safety control prevents operation of the RotoClone if the water level in the unit is too low.

Model A Control

This water supply system contains a fill valve, strainer, solenoid valve, level electrode, and a timing relay. The electrode is used to open and close the solenoid valve to maintain a constant water level in the RotoClone without continuous overflow to drain. It should be noted that high concentration of dissolved solids may result with the Model A controls since there is no "blow down" of liquid. This may necessitate periodic replacement of the water.

Rugged Construction for Longer Life

The Type N RotoClone is available for both normal and heavy-duty service. Heavy-gauge hot rolled steel is used for the standard model. For corrosive environments, a coal-tar epoxy coating or stainless steel construction is available.

Low Maintenance Requirements

Designed for continuous operation with minimum service, the absence of intricately shaped surfaces and narrow air passages minimizes the build-up of dust deposits or the blocking of restricted openings. Access doors with quick-opening handles provide accessibility to the interior of the Type N RotoClone.

Fits Limited Space Applications

The Type N RotoClone can be engineered to accommodate special conditions or space limitations, such as the presence of an existing exhaust system or low headroom. Our extensive experience in the design and manufacture of wet collectors positions us to deliver a top-quality solution that will meet your specific application requirements.

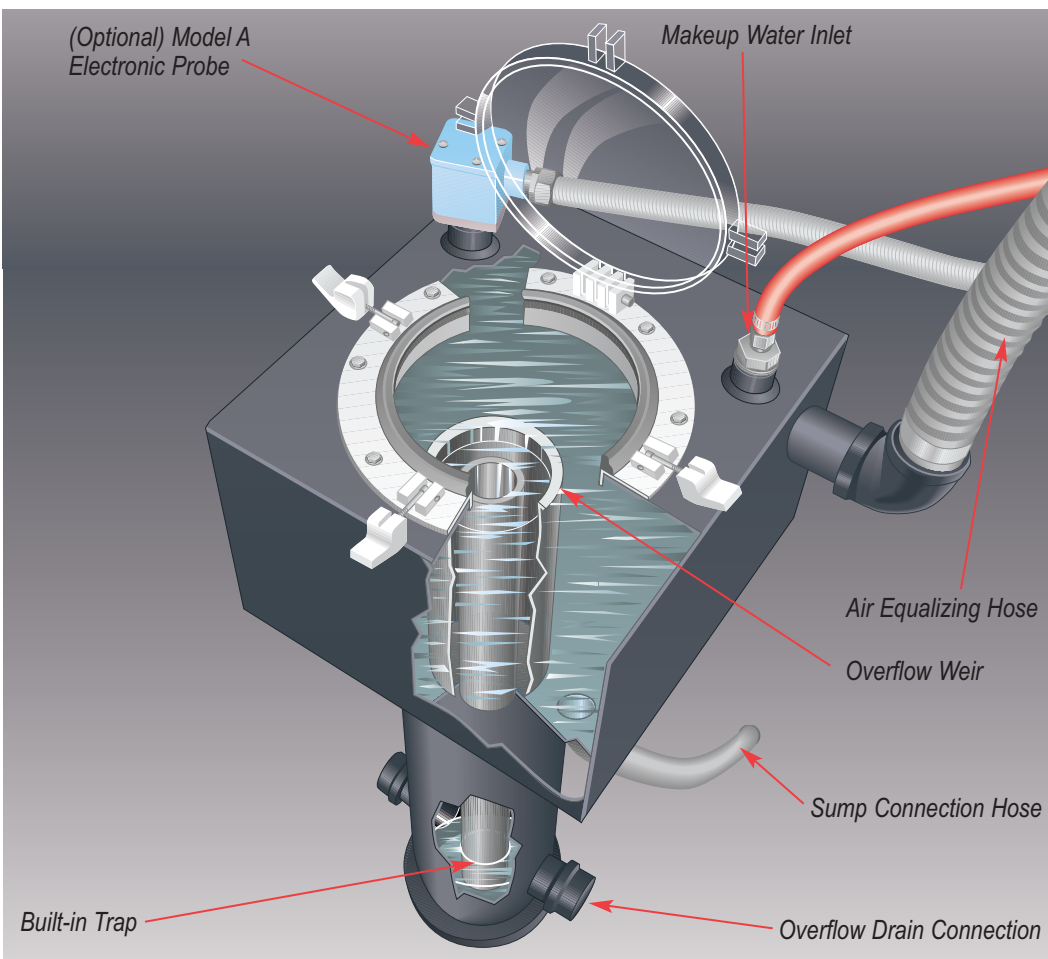

Model A Water Level Control Box



Arrangement B, Size 6 or smaller, wide-spaced chevron water eliminators remove entrained water from the clean air

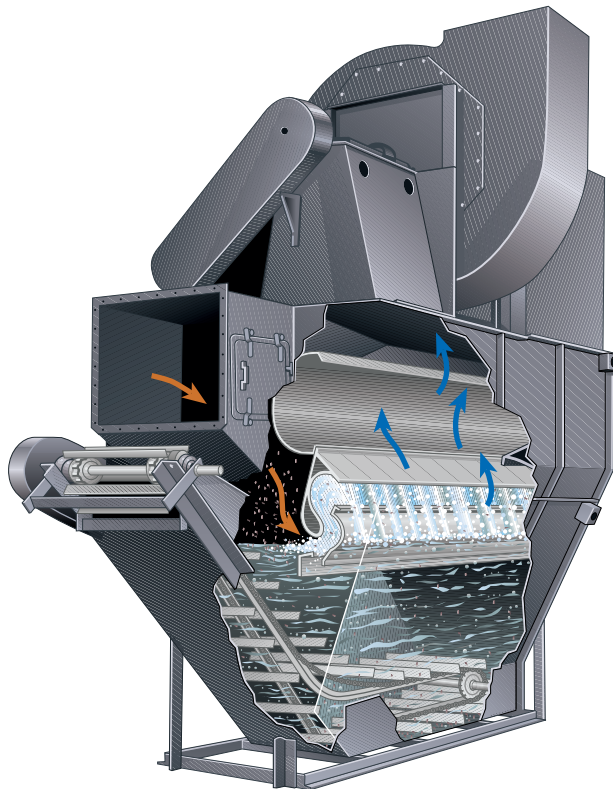

Arrangement C, Size 8 or larger, de-entrainment baffles remove water from the clean air

Sludge Disposal Methods

There are three hopper designs available for disposing of collected material:

Arrangement B:

Flat bottom design for manual removal of collected material.

Arrangement C

Hopper with drag-type sludge ejector for automatic dewatering and sludge removal.

Arrangement D

Pyramid hopper for sluicing collected material to a process or disposal point.

Arrangement B Manual Sludge Removal

Type N RotoClone, Arrangement B, is designed for reduced height and low initial cost. Since collected material must be removed manually, this arrangement is appropriate for applications where dust loadings are light, such as, the exhaust of buffing, polishing, and metal working; packaging, sorting, and weighing operations; and chemical products.

In units with a single impeller, one side of the reservoir is sloped to facilitate removal of the collected material. With the double impeller units, it is usually necessary to drain the reservoir for sludge removal. Access door location and interior headroom is provided to facilitate shoveling collected material to a tote box or sludge chute.

Arrangement C Automatic Sludge Removal

Type N RotoClone, Arrangement C, is designed to reduce manual removal of collected material. It is recommended for moderate and heavy dust loads, for applications requiring continuous 24-hour service, and where manual removal of the sludge would be unreliable or cost prohibitive. This arrangement is frequently used for foundry sand handling applications; abrasive cleaning, buffing, and grinding; material handling; and dryer and process exhaust.

Steep sides in the hopper minimize material build-up, while the sludge ejector mechanism provides easy removal of collected material. The ejector assembly is designed for heavy-duty service and driven by a small geared motor. The chain and sprockets of the ejector are fabricated from wear-resistant alloys. A slow chain speed, approximately two feet per minute, combined with a long steep ejector chute assures effective dewatering of the solid material as it is ejected. Scrubbing water is conserved and make-up water is reduced.

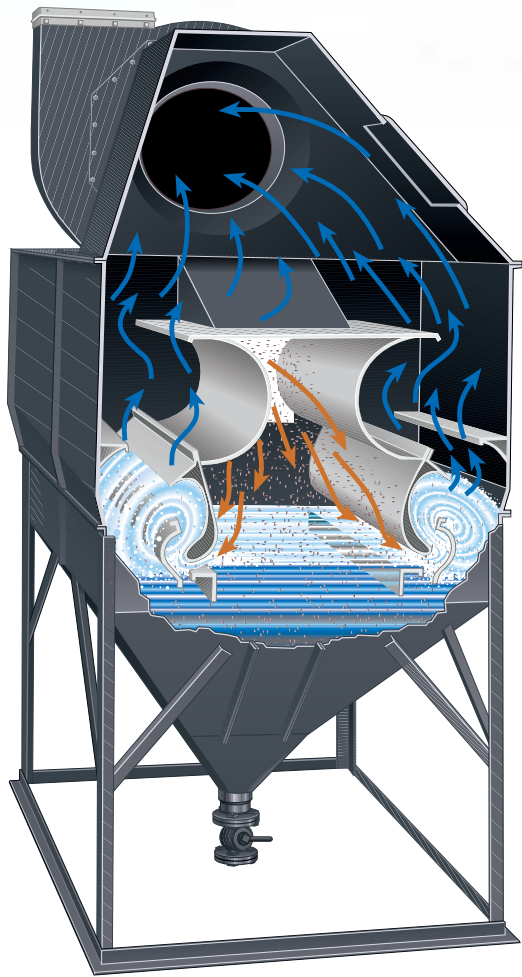

Arrangement D, de-entrainment baffles remove water from the clean air

Arrangement D Continuous Sluicing

Type N RotoClone, Arrangement D, is designed to sluce collected material through the hopper into a process or disposal point. Sluicing may be continuous or intermittent. This arrangement is recommended for material handling applications in the chemical and rock products industries; and dust abatement on crushers, screens, and transfer points for mining and rock products.

To maintain the scrubbing water at the proper operating level, a constant supply of make-up water and drainage is required.

Performance Data (Pressure Loss)

The Pressure Loss chart shows the total pressure losses through the Type N RotoClone in relation to the flow rate through the impeller. The total pressure losses are measured by subtracting the static pressure at the collector outlet flange from the static pressure at the inlet flange. The size of the Type N RotoClone corresponds to the length of the impeller (i.e., a size 6 Type N will have an impeller length of six feet). The Type N is normally sized based on a gas velocity of 1000–1200 CFM per foot of impeller.

Example: Select a size RotoClone for given conditions of 22,000 ACFM @ 70°F db design pressure drop = 6–7" w.g.

Sizing: Since inlet condition is ambient air, cooling by the Type N RotoClone can be ignored.

If a size 20 is selected, the flow rate is $\frac{22,000}{20} = 1100$ CFM/ft. impeller.

The RotoClone can be selected for 1100 CFM/ft. of impeller and a pressure drop of 6.9" w.g. or 8.6" w.g. A pressure drop of 6.9" is selected since it meets the design conditions.

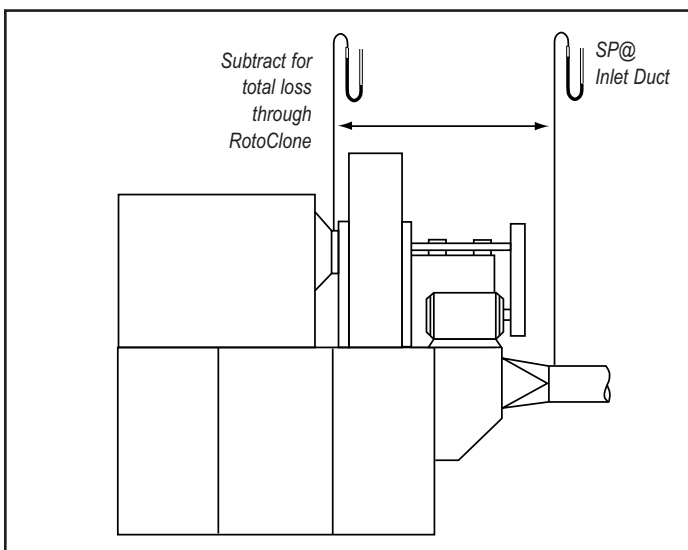

Schematic diagram showing method of measuring pressure loss through RotoClone

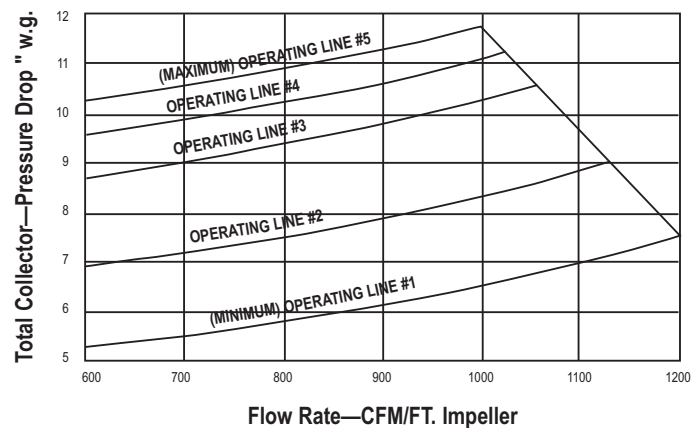



Typical Applications

Explosive Dust

- TNT/Gunpowder Plants
- Airbag Manufacturing
- Light Metals (Al, Mg, Ti) Processing/Machining
- Fertilizer

Material Handling

- Conveying
- Dumping
- Mixing

Rubber Grinding

- Rubber Rolls
- Tire Buffing

Metalworking

- Grinding
- Cutting
- Buffing/Polishing

Chemicals

- Conveying
- Dumping
- Mixing

Mining

- Crushing
- Screening
- Material Handling Dryers

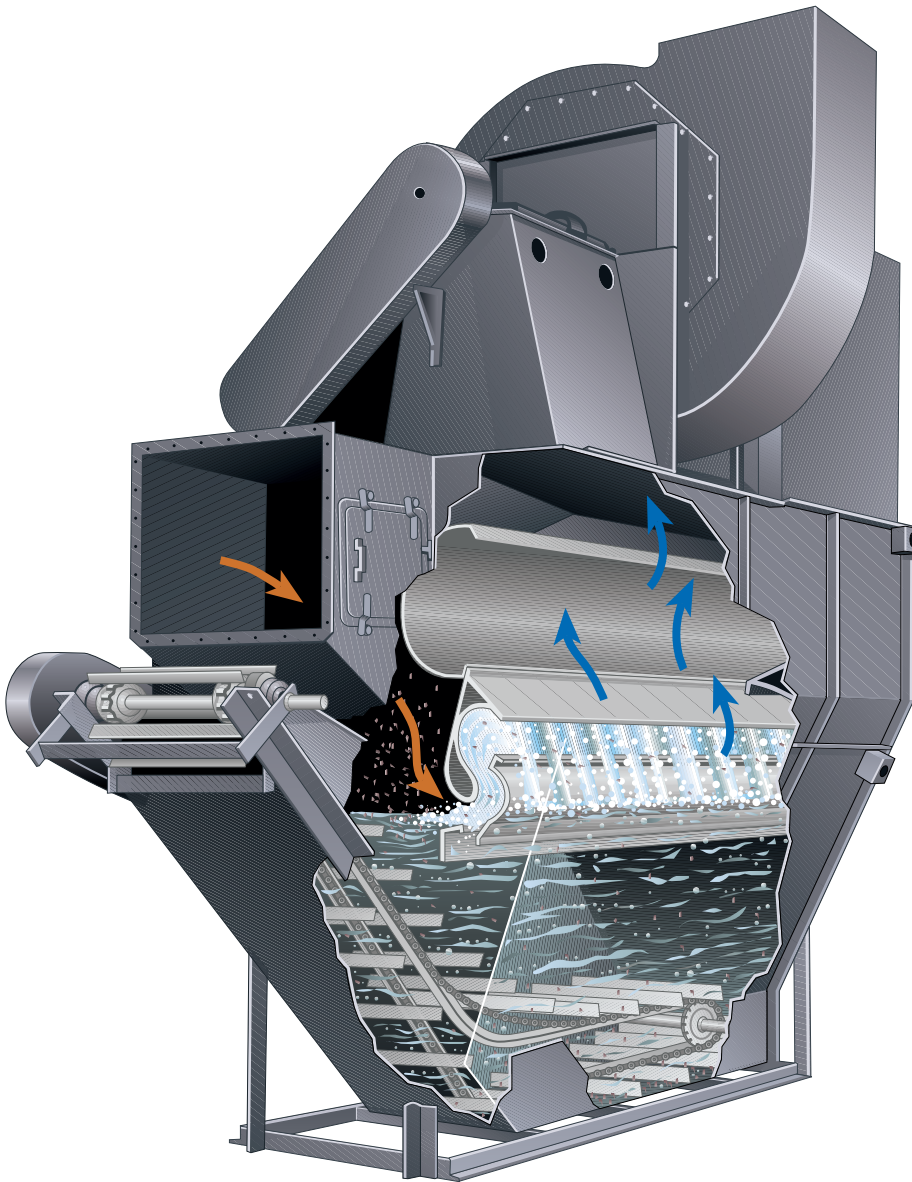

AmericanAirFilter®

Type N RotoClone®

Normal Water Supply Rates

AAF Type N RotoClones

RotoClone Size	Arrangement B	Arrangement C	Arrangement D
	GPM Supplied 20 PSI	GPM Supplied 20 PSI	GPM Supplied 40 PSI
1½	.5	.5	6.0
2½	.5	.5	6.0
4	.5	.5	8.0
6	.5	.5	8.0
8	.5	1.0	11.0
12	.5	1.0	14.0
16	.5	1.0	22.0
20	1.0	1.5	22.0
24	1.0	1.5	34.0
28	1.0	2.5	40.0
32	—	2.5	40.0
36	—	2.5	40.0
40	—	2.5	40.0
44	—	2.5	60.0
48	—	2.5	60.0

With high temperature air, evaporation must be compensated for by increased water rates. A safe approximation will be 0.2 gpm of additional water per 1000 cfm for each 100°F of temperature reduction in the RotoClone.

Shipping and Operating Weights

AAF Type N RotoClones

Size	Arrangement B			Arrangement C			Arrangement D		
	*Operating Wt. Lbs. w/Fan	Water Cap. Gal.	Shipping Weight w/Fan	Operating Wt. Lbs. w/Fan	Water Cap. Gal.	Shipping Weight w/Fan	Operating Wt. Lbs. w/Fan	Water Cap. Gal.	Shipping Weight w/Fan
1½	2,600	90	1,600	6,300	300	2,300	3,700	120	2,100
2½	2,800	90	1,700	6,400	300	2,400	3,800	120	2,200
4	4,200	140	2,300	9,500	470	3,200	5,200	180	2,800
6	5,900	220	3,000	11,400	540	4,200	8,100	330	3,700
8	8,200	295	4,200	13,200	530	6,100	10,700	390	5,500
12	11,200	440	5,300	16,500	650	7,800	15,000	605	6,900
16	14,000	510	7,200	28,500	1,370	10,200	20,800	900	8,800
20	17,900	730	8,100	33,600	1,650	11,600	26,800	1,250	10,100
24	21,900	880	10,100	40,300	1,950	14,300	31,400	1,290	14,200
28	24,900	1,025	11,900	46,000	2,220	16,400	36,800	1,510	16,600
32	—	—	—	51,100	2,500	17,700	43,500	1,925	17,800
36	—	—	—	56,300	2,775	19,300	50,000	2,250	20,000
40	—	—	—	64,500	3,050	23,800	58,300	2,500	24,900
44	—	—	—	70,200	3,330	25,800	62,900	2,690	27,000
48	—	—	—	76,100	3,610	27,900	67,400	2,880	29,000

*Operating weights are based on the maximum sludge capacity with a sludge weight of 100 lbs. per cubic foot.

World Class Quality

Many of the technologies used to control air pollution were originally developed by AAF. Our facilities are specifically designed to manufacture and test complex air pollution control products. During the entire production process, our operations are governed by our ISO 9001 certified quality system.

Special Conditions

Special situations or space limitations may require that the Exhauster be positioned someplace other than the standard top mount. If this is necessary, the Exhauster can be mounted in a remote location. For positive pressure operations, the Exhauster can also be located in front of the Type N RotoClone.



10300 Ormsby Park Place Suite 600
Louisville, Kentucky 40223-6169
www.aafintl.com
Customer Service 800.477.1214
Fax 800.254.3019



AAF has a policy of continuous product research and improvement and reserves the right to change design and specifications without notice.

ISO Certified 9001:2000

©2008 AAF International
The USGBC Member logo is a trademark owned by the U.S. Green Building Council and is used by permission.